

Team 16: Text2Touch

Anthony Nykamp, Aubree Jo Peters, Owen Pruum, Christine VanOyen, Calvin University, Grand Rapids, Michigan

Introduction



Team 16, Text2Touch set out to design and prototype an affordable braille printer. In the United States alone, over 8 million people are affected by blindness and visual disabilities, yet there is a lack of publicly available braille printers, and those that are available to purchase can cost a few thousand dollars. Therefore, a need was seen to create a braille printer that is less expensive, providing individual households and communities with the ability to purchase and use a braille printer. Braille is beneficial as it helps with navigation of public spaces, teaches spelling, grammar and punctuation, and it aids in brain development, building and strengthening connections between different parts of the brain.

Mechanical



XY Table

A Makeblock XY table kit was used as the basis for the braille printer. Part of the XY table was used to move the embossing mechanism along one axis of translation using a belt and stepper motor.

Embossing Mechanism

The embossing mechanism creates the braille dots by indenting the paper. It consists of a 3D printed part fastened to machined aluminum.

Paper Feed

The paper feed was designed using the rolling mechanism from a paper towel dispenser. The 3D printed base plate incorporates mounts to stabilize the axle that the rollers rotate around. There are two rollers that make up this system. One of the rollers is motorized to advance the paper after a line of text is completed.

Electrical



Arduino

An Arduino microcontroller was chosen as the brain of the braille printer because they are relatively simple to program and have as much I/O as the printer needs.

Hardware

The punching mechanism and the paper feeder are controlled by stepper motors, which are controlled from the Arduino using L293D stepper motor controller chips. The printer also uses 12V solenoids to punch braille dots.

Software

The software was designed so that the Arduino can read in text via the USB serial port, translate the text into 6-bit braille characters, and print by moving and firing the punches.



Left to right: Anthony Nykamp, Aubree Peters, Christine VanOyen, Owen Pruum.

Objectives

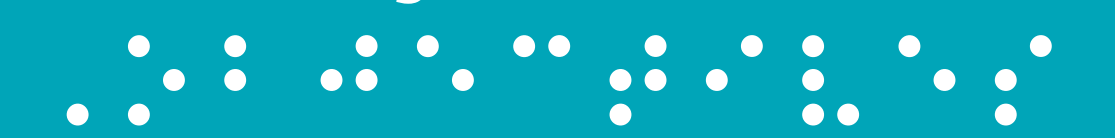

The team set out to create a printer that...

- Prints all 63 characters of braille text according to braille text standards.
- Receives document information through USB cable
- Prints on standard braille paper
- Receives information as text file
- Is composed of sustainable materials

Braille

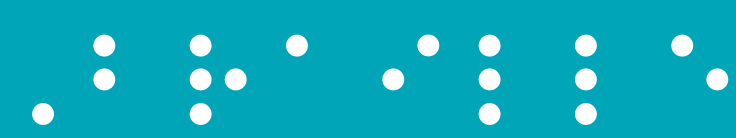

Braille Character Standards

Each character produced by the braille printer must be printed on standard braille paper and be in accordance with ADA standards. To satisfy this requirement for each braille character, the printer requires high precision translation and utilizes parts from an official braille writing kit.

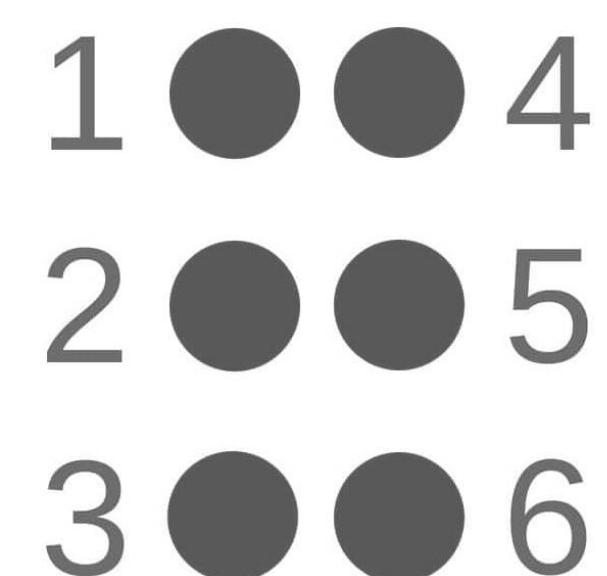

Results



The final design of the printer is capable of printing all 63 braille characters. The word file is converted to braille text and then sent to the printer by means of USB connection. The printer is able to punch 3 dots at a time.

Functionality

The team designed and prototyped a printer that is able to print all 63 braille characters.

Affordability

The total cost of components, not including labor costs, to build the Text2Touch printer is \$380. This is a fraction of the cost of the current market price.

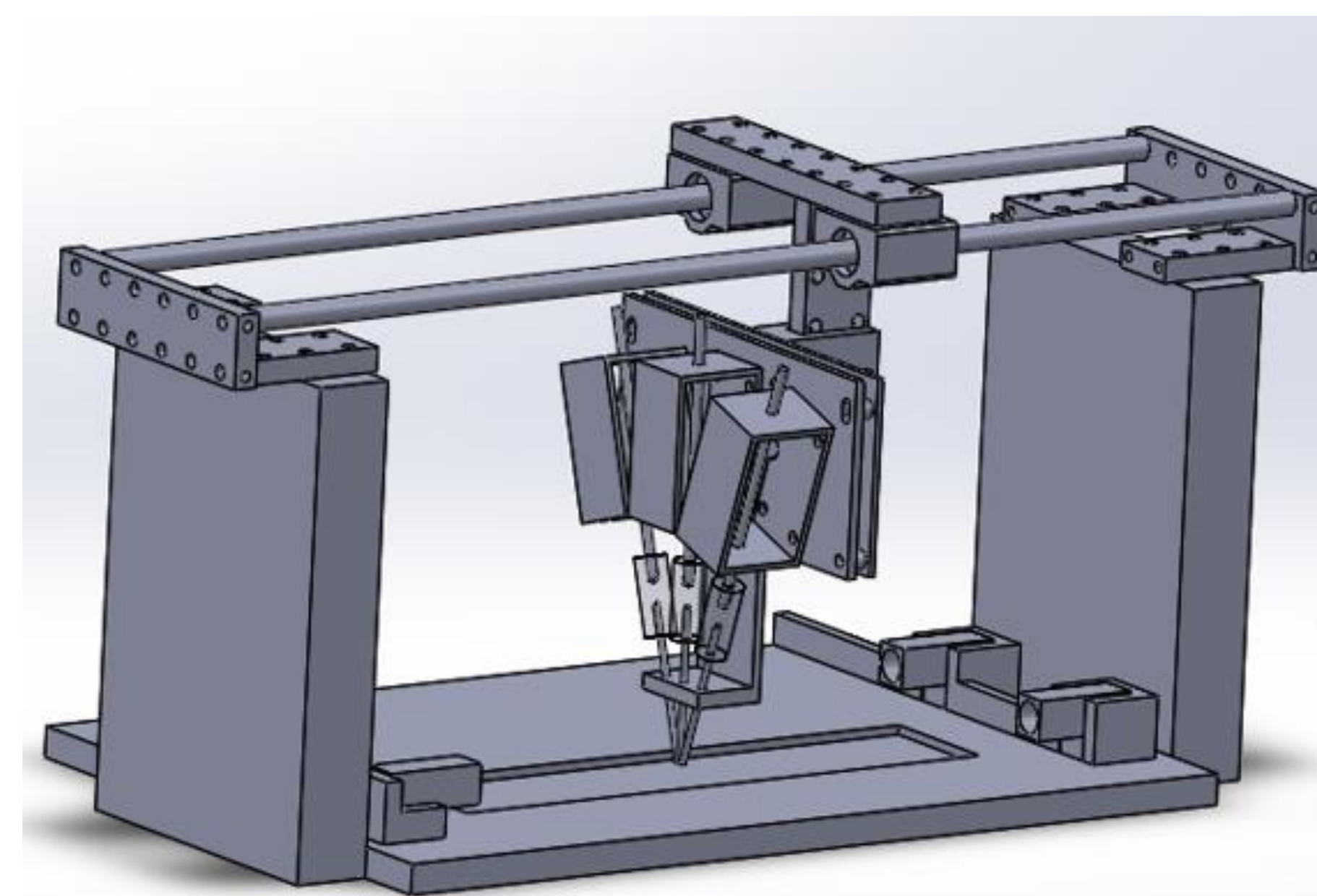

Final CAD model of Text2Touch Printer

Acknowledgements

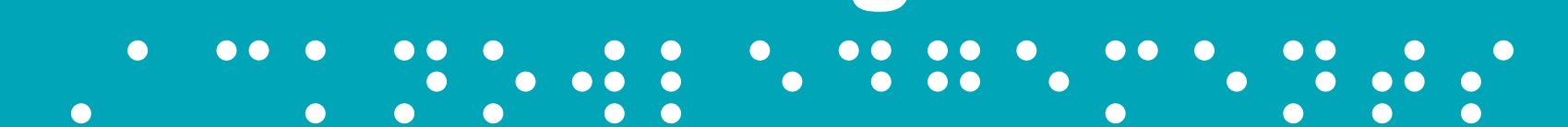

Professor Renard Tubergen, PhD, PE
Chris Sorensen